

LAMPIRAN – LAMPIRAN

Lampiran 1 Vending machine



Lampiran 2 Struktur dalam vending machine



Lampiran 3 Bagian keluaranya produk

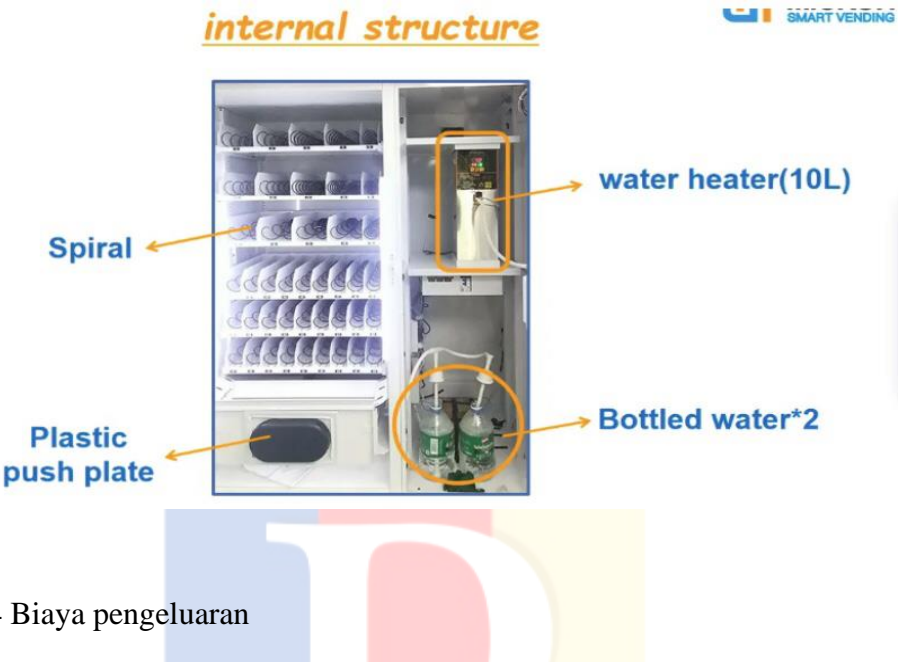

Lampiran 4 Biaya pengeluaran

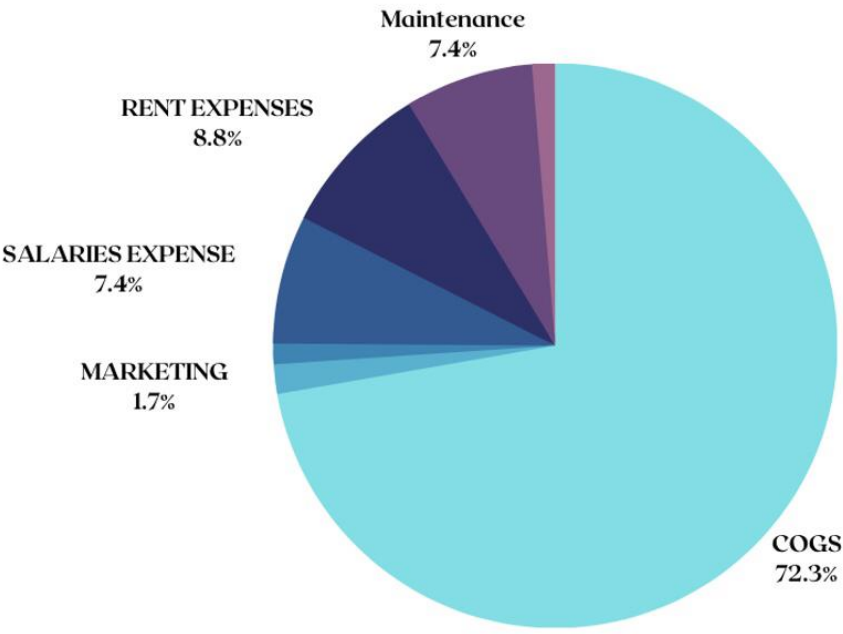

Lampiran 5 Proses produksi

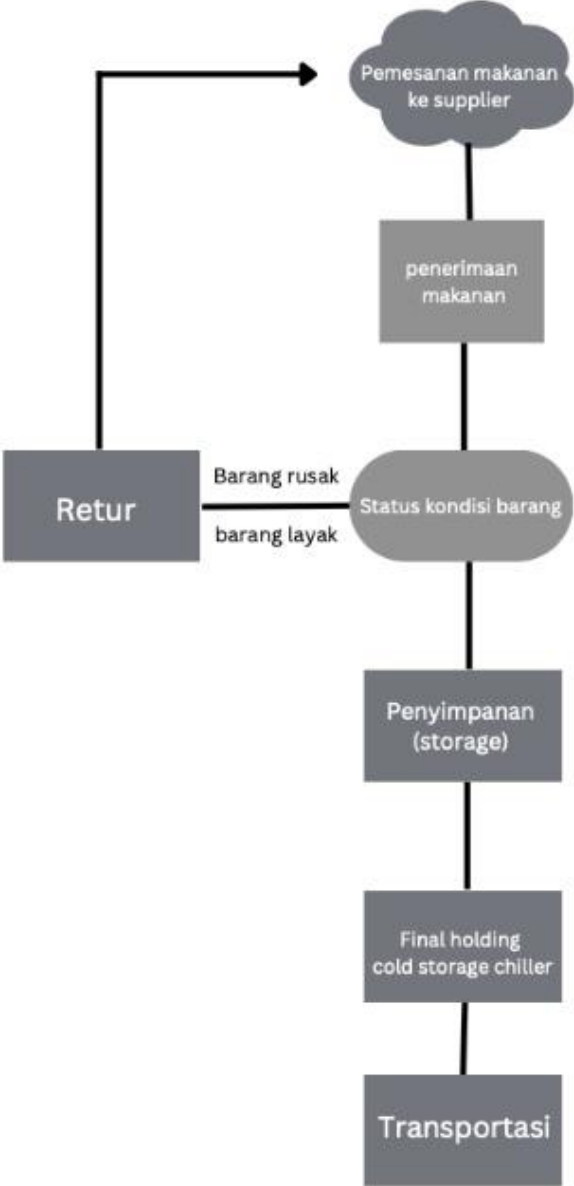

Lampiran 6 Sketsa vending machine

Machine dimension

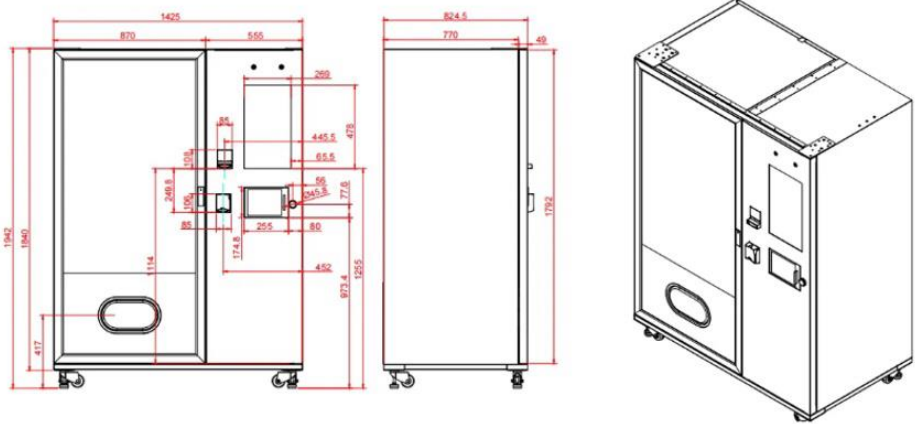

Lampiran 7 Logo Noo.Chin



Lampiran 8 Proses bisnis

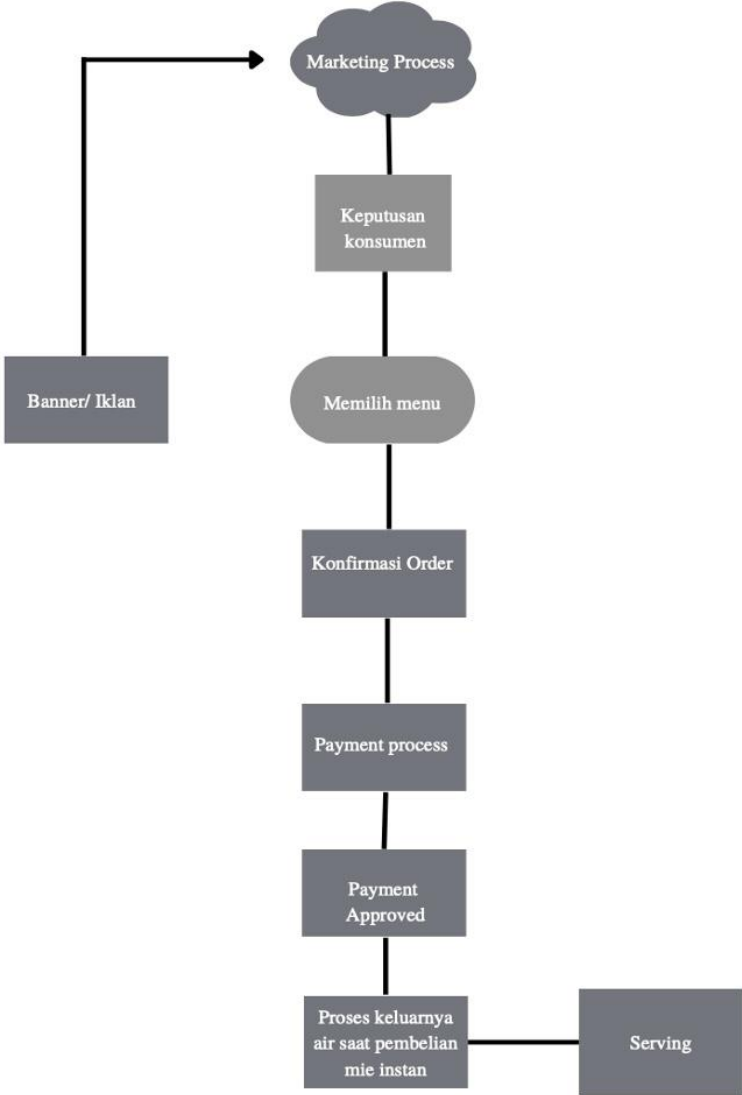

Lampiran 9 Stuktur organisasi

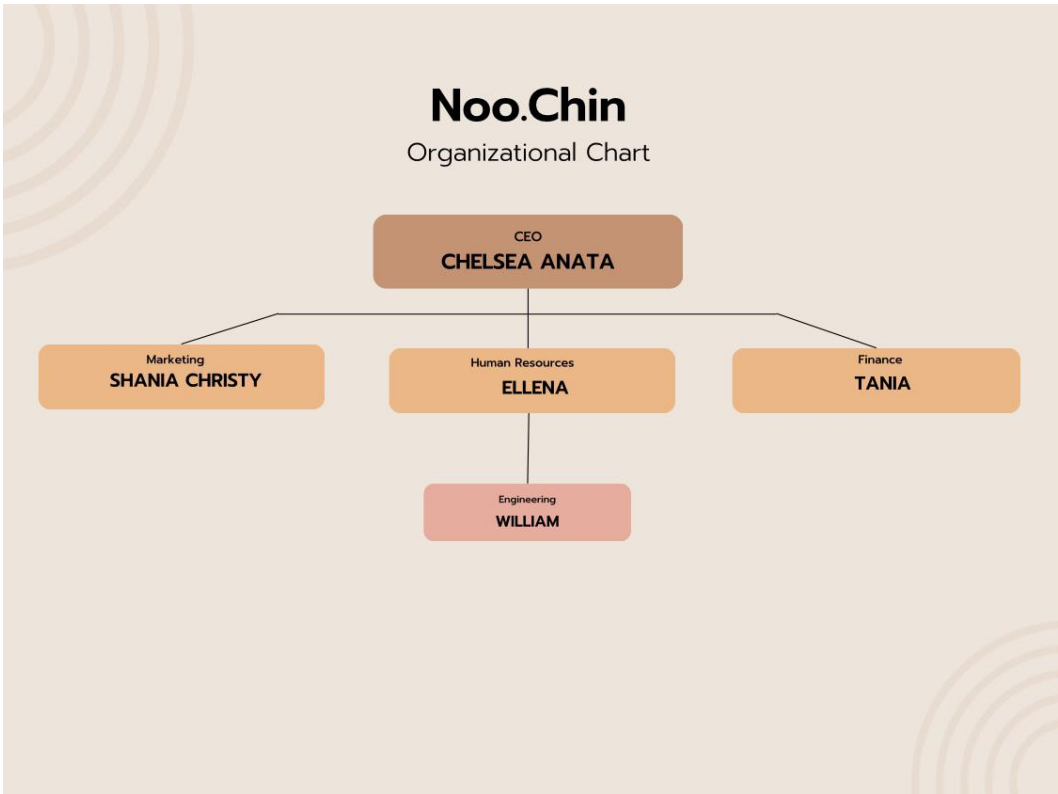

Lampiran 10 Perencanaan persiapan bisnis 1

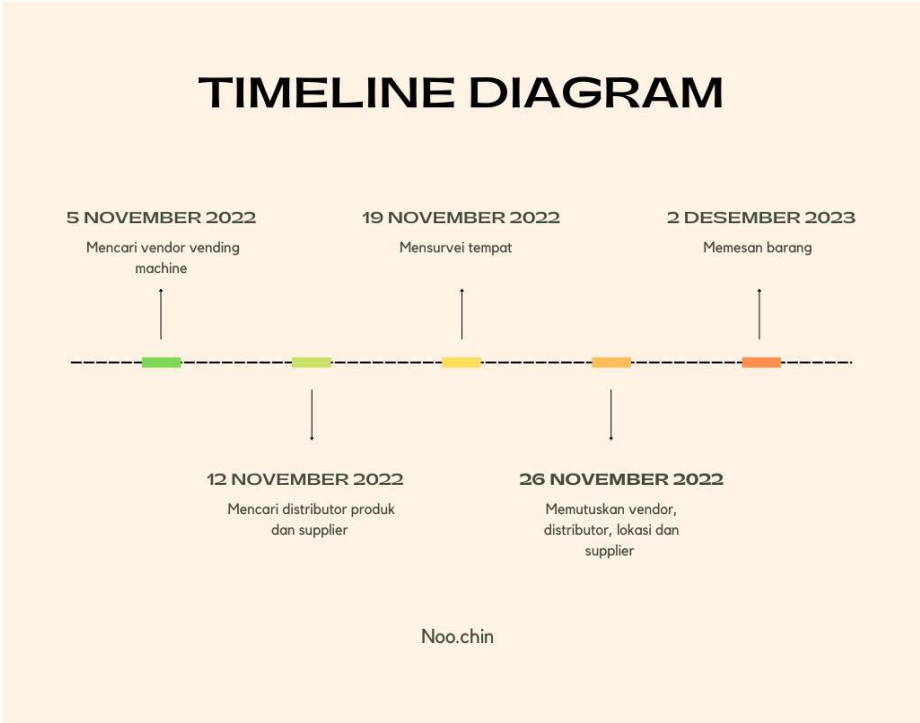

Lampiran 11 Perencanaan persiapan bisnis 2

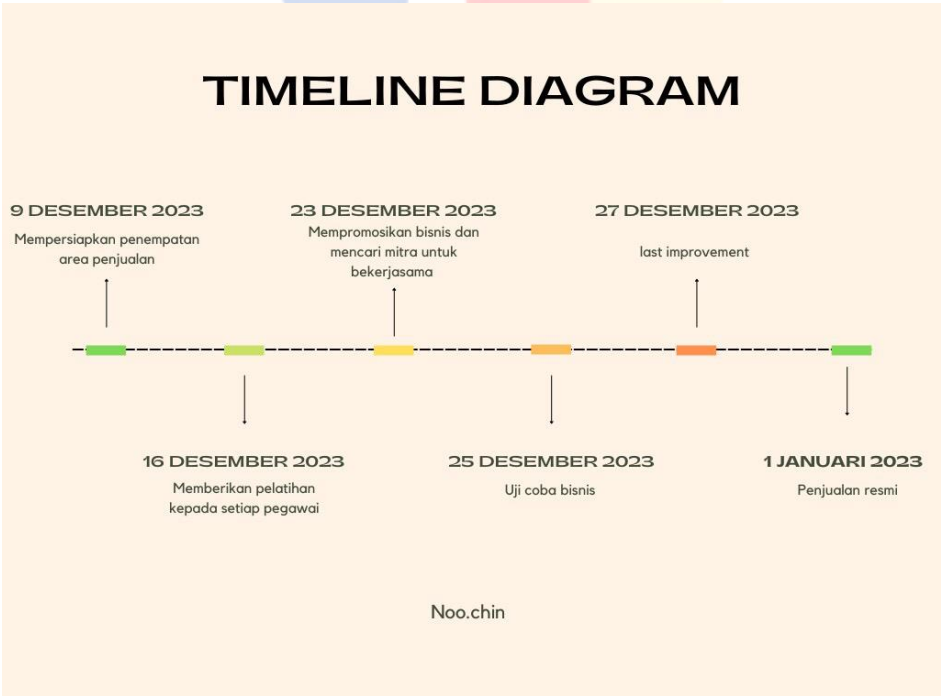

Lampiran 14 Pengeluaran operasional

Nama Kelompok		TEAM Noo.Chin												
Tgl Update terbaru		09/01/23												
OPERATING EXPENSE (OPEX) REPORT														
Period: Jan-Dec 2023														
EXPENSE COSTS		JAN	FEB	MAR	APR	MAY	JUN	JUL	AUG	SEP	OCT	NOV	DES	TOTAL
Saya Operasional:														
Electricity	160.000	160.000	160.000	160.000	160.000	160.000	160.000	160.000	160.000	160.000	160.000	160.000	160.000	1.920.000
Salary	2.600.000	2.600.000	2.600.000	2.600.000	2.600.000	2.600.000	2.600.000	2.600.000	2.600.000	2.600.000	2.600.000	2.600.000	2.600.000	31.200.000
Rent	1.000.000	1.000.000	1.000.000	1.000.000	1.000.000	1.000.000	1.000.000	1.000.000	1.000.000	1.000.000	1.000.000	1.000.000	1.000.000	12.000.000
Maintenance	-	-	1.000.000	-	-	1.000.000	-	-	1.000.000	-	-	1.000.000	-	4.000.000
Transportation	180.000	180.000	180.000	180.000	180.000	180.000	180.000	180.000	180.000	180.000	180.000	180.000	180.000	2.160.000
Tax	-	-	-	-	-	-	-	-	-	-	-	-	-	2.949.635
Total Operating Expense	3.940.000	3.940.000	4.940.000	3.940.000	3.940.000	4.940.000	3.940.000	3.940.000	3.940.000	4.940.000	3.940.000	3.940.000	7.889.635	54.229.635
MARKETING EXPENSE														
Daily Vloger	500.000	-	-	500.000	-	-	-	500.000	-	-	-	500.000	-	2.000.000
Banner & Design	270.000	-	-	-	-	270.000	-	-	-	-	-	-	-	540.000
Total Marketing Expense	770.000	-	-	500.000	-	270.000	-	500.000	-	-	-	500.000	-	2.540.000
	4.710.000	3.940.000	4.940.000	4.440.000	3.940.000	5.210.000	4.440.000	4.440.000	3.940.000	4.940.000	4.440.000	3.940.000	7.889.635	56.769.635
4*3 bensin per jalan parkir tol	12 15000 20km 0 0 180000		10 150000					2.5%						117.985.410

Lampiran 15 Pengeluaran peralatan dan investasi awal

Nama Kelompok		TEAM Noo.Chin											
Tgl Update terbaru		09/01/23											
CAPITAL EXPENDITURE (CAPEX) REPORT													
ITEM	Unit	Price/unit	Unit Needed	TOTAL									
Contoh Peralatan/Aset:													
Vending Machine	1	43.500.000	1	43.500.000									
Bea Cukai	1	4.350.000	1	4.350.000									
Biaya Impor	1	17.500.000	1	17.500.000									
TOTAL CAPEX INVESTMENT				65.350.000									
WORKING CAPITAL PROJECTION (Modal Kerja)													
Jumlah uang yang diperlukan untuk membuat produk batch 1 (All COGS produksi batch 1)													65.350.000
TOTAL INVESTMENT NEEDED													
Jumlah modal investasi awal = CAPEX + OPEX bulan 1 + Working Capital batch 1													79.334.650

Lampiran 16 Proyeksi arus kas

Nama Kelompok		TEAM Noo.Chin											
Tgl Update terbaru		09/01/23											
CASH FLOW													
Period: Jan-Dec 2023													
	JAN	FEB	MAR	APR	MAY	JUN	JUL	AUG	SEP	OCT	NOV	DES	NOTES
Capital Investment	79.334.650	-	-	-	-	-	-	-	-	-	-	-	Jumlah modal awal
Cash Increase	11.425.350	12.138.370	11.442.850	11.061.125	12.019.775	11.510.865	11.851.560	11.488.740	11.535.160	11.709.450	11.814.690	11.391.600	Jumlah seluruh uang masuk di bulan bersangkutan
Cash Decrease	79.334.650	3.940.000	4.940.000	4.440.000	3.940.000	5.210.000	4.440.000	3.940.000	4.940.000	4.440.000	3.940.000	7.889.635	Jumlah seluruh uang keluar di bulan bersangkutan
Closing Cash Balance	11.425.350	19.623.720	26.126.570	32.747.695	40.827.470	47.126.335	54.539.895	62.088.635	64.683.795	75.953.245	83.827.935	87.329.900	

Lampiran 17 Breakeven point

Nama Kelompok	Noo.Chin		
Tgl Update terbaru	09/01/23		
BEP=	Revenue per unit	Fixed costs	Variable cost per unit
		-	
BEP=	Rp 262.795.000,00	Rp 79.334.650,00	Rp 180.175.100,25 /tahun
BEP=		Rp 79.334.650,00	
		Rp 82.619.899,75	
		0,96023658 tahun	
approximately		11,52283896 bln	
Berdasarkan perhitungan BEP berikut, diperkirakan akan mencapai titik BEP pada bulan ke 11 hari ke 16			

Lampiran 18 Proyeksi titik balik modal

Nama Kelompok	Noo.Chin			TEAM Noo.Chin
Tgl Update terbaru	09/01/23			
RETURN ON INVESTMENT (ROI)				
ROI Formula				
$ROI = \left(\frac{\text{Gain From Investment} - \text{Cost Of Investment}}{\text{Cost Of Investment}} \right) \times 100$				
<small>What does it mean? Gain from Investment: Refers to your net income or profit for the year Cost of Investment: Refers to the total amount you invested</small>				
ROI =	87.329.900	-	79.334.650	x 100%
		79.334.650		
=	10,08	%		